

# Double Case PD Flowmeters

Technical Bulletin

The trusted specialist manufacturer of high precision instruments that relies upon the accurate measurement of fluid volumes

Trust in us  
Our Quality Counts



# PETROL®

PD Flowmeters since 1970

## Double Case PD Flowmeters

### Main Features

- ✓ **Excellent Accuracy and Repeatability:**  
Accuracy :  $\pm 0,15\%$  for fiscal applications and  $\pm 0,5\%$  for general purpose  
Repeatability:  $\pm 0,02\%$
- ✓ **Low Pressure Drop:** The straight-through path and floating rotor design create a very low pressure drop at maximum flow
- ✓ **Production Line:**  
Flange size: 1" ÷ 16"  
Max. Flow rate: 2,000 m<sup>3</sup>/h  
Max. pressure: 150 bar  
Max. temperature: 250 °C  
Max. Viscosity: 50.000 cP
- ✓ **Materials of Construction:** A broad range of materials are available to meet customer application requirements
- ✓ **Floating Type Rotors:** Rotors never touch each other but are synchronized by timing gears mounted outside the measuring chamber. Rotors are not therefore subject to wear and PD flowmeter does not need re-calibration with time due to wearing
- ✓ **Magnetic transmission:** sealing between the wetted parts and the dry parts of the PD flowmeter is of static type, and this fully guarantees against any leakage of the flowing liquid
- ✓ **Wide Range of Accessories:** A complete line of accessories are available to meet a broad range of applications. Intrinsically safe and explosion proof versions available
- ✓ **Conformity with International Standards:** PED, ATEX, OIML R117, API MPMS, ISO 9001, ISO 14001, ISO 45001, IP/NEMA, LR
- ✓ **International Approvals for Fiscal Applications:** Indonesian Approval (MIGAS), Russian Approval, Nigerian Approval (DPR), Chinese Approval (PAC), Hellenic Metrological Approval, Malaysian Approval (NMIM/SIRIM), Kazakhstan Approval, MID Certified as component for use within a measuring system as agreed within WELMEC

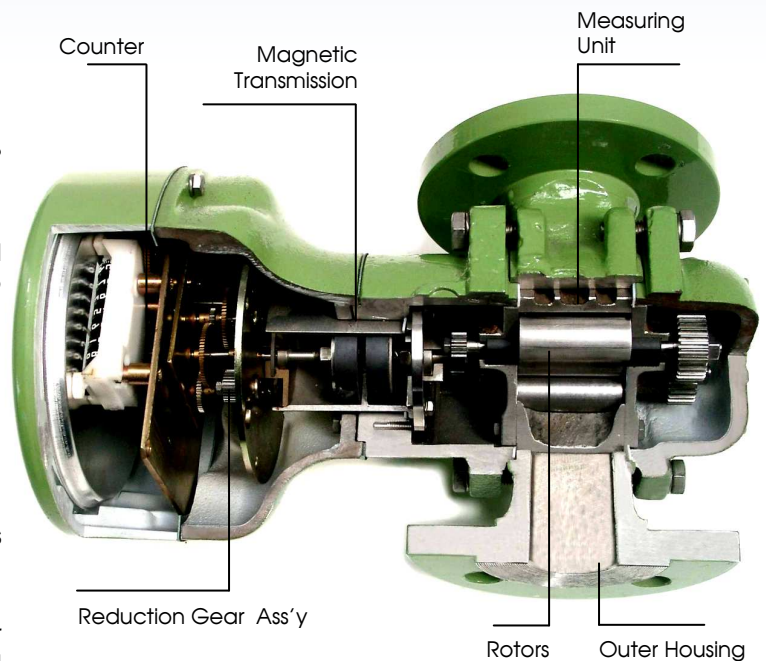

### Main Benefits

- ✓ **Compact Design:** No upstream or downstream pipe lengths are necessary
- ✓ **Long Service Life:** The rotors never touch each other nor they touch the other parts composing the "base volume" therefore they are not subject to wear. Plus the magnetic transmission of the rotors movement eliminates the maintenance and product leakage associated with a mechanical linkage method
- ✓ **Double Case Construction:** Measuring Unit can be removed without dismounting the entire PD flowmeter from the line and may be maintained as well as functionally rechecked independently from outer housing
- ✓ **Highest Performance on Viscous Products:** Recommended for Crude Oil Custody Transfer Applications
- ✓ **Possibility to use it without power supply:** Suitable for any application
- ✓ **Direct reading of the volume:** Excellent accuracy and repeatability
- ✓ **Flexibility to customer needs:** Customized solutions
- ✓ **No Special Tools and No Skilled Person Required:** Easier Maintenance
- ✓ **Not subject to air hammer effect and slug damages:** Longer life



## PD Flowmeters since 1970

### Double Case PD Flowmeters

#### Operating Principle

The two rotors, engineered and manufactured in such a way they never touch each other nor the measuring unit components, are alternatively driven by the timing gears coupled on rotor shafts just outside the measuring chamber.

As shown in the operating scheme, the liquid flowing inside the PD flowmeter pushes the rotor on the right, which is in condition of unbalanced pressure, to rotate clockwise; contemporarily the rotor on the left, being driven by the timing gears, is forced to rotate counter clockwise.

After a 90° rotation, the rotors are in a reciprocal position when compared to the initial one and therefore it is the rotor on the left which, pushed from the liquid, rotates counter clockwise driving, through the timing gears, the rotor on the right. During these operating cycles, the volume generated between the rotors and the components of the measuring chamber determine the "base volume" of the instrument.

A complete rotors' rotation generates four "base volumes". By transmitting the number of rotors' rotations to the register the volume flown through the PD flowmeters is displayed.

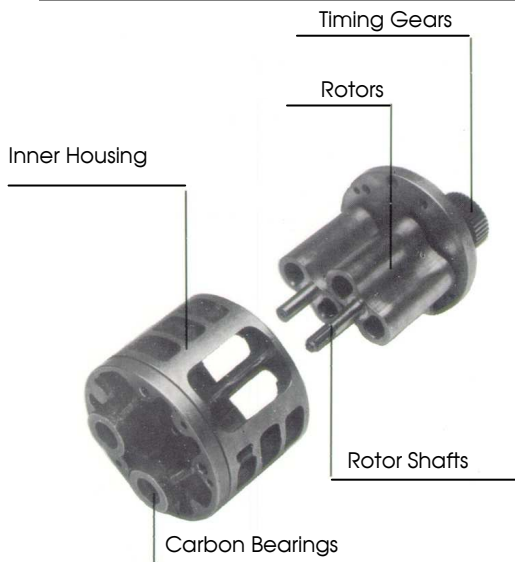
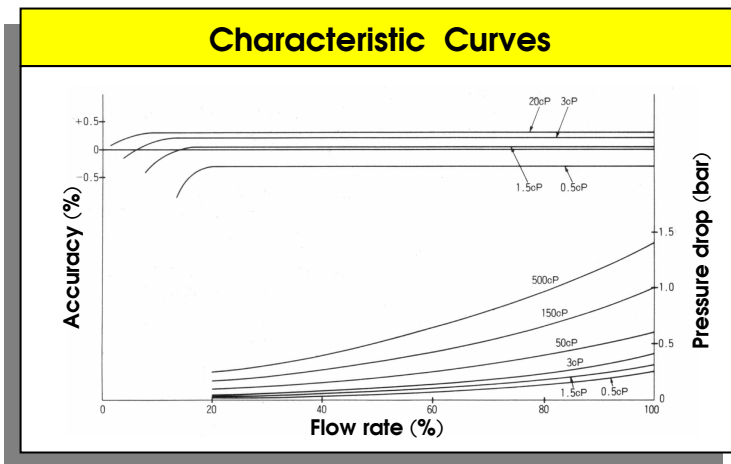
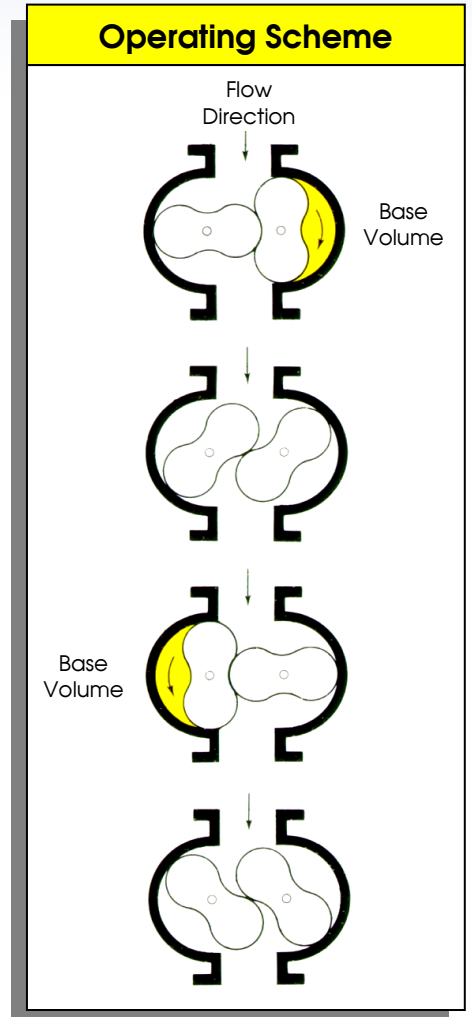

#### Exploded Views

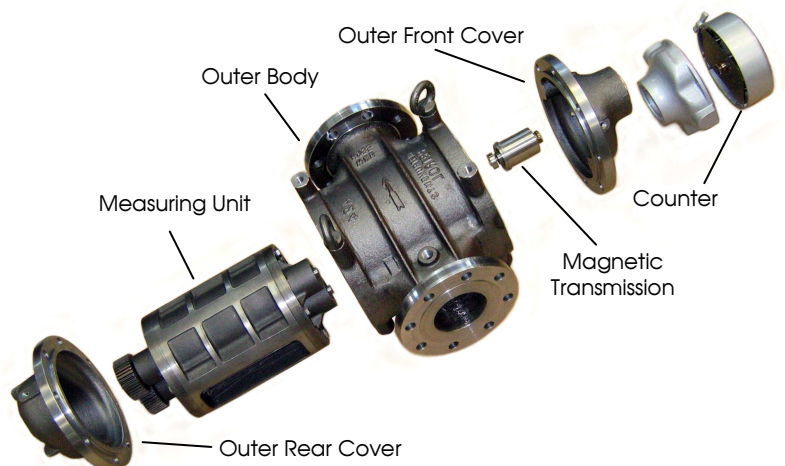

# PETROL®

## PD Flowmeters since 1970

### Double Case PD Flowmeters

#### How to select

##### Pd Flowmeter Type

- F standard
- FJ jacketed

##### Max Operating Pressure

(See table)

##### Pd Flowmeter Model

From the table "flow rate ranges" select the PD flowmeter model more suitable for the specific needs with reference to the type of liquid to be metered and to its operating viscosity.

##### Counter

From the table "counters" select the model more suitable for the specific needs.

For eventual accessories add the following letters:

- P for electric pulse transmitter;
- N for pneumatic pulse transmitter;
- T for automatic temperature compensator.

For operating temperatures above 100 °C the PD flowmeter is equipped with mod. AK-x air-fin cooler. Adaptors to incline the counter by 45° or 90° are also available.

##### Construction Materials

See below "tables".

PD flowmeters in plastic materials (Moplen and PVC) are available on request.

FA 24 - 12 - F 8

#### Identification Code

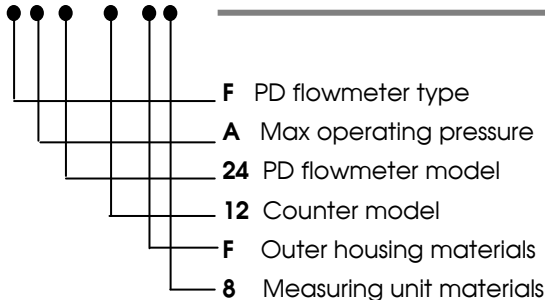

Counters	
<b>Mod. 12</b>	Mechanical counter with 10 figures non reset type totalizer (8 on digits plus 2 on dial).
<b>Mod. 22</b>	Mechanical counter with 8 figures reset type totalizer (6 on digits plus 2 on dial) and with 8 digits non reset type totalizer.
<b>Mod. VR</b>	Counter with 5 large figures reset type totalizer, 8 digits non reset type totalizer, 5 figures settable through single push buttons preset counter (optional) and 5 digits zero-start or 7 digits accumulative type ticket printer (optional).
<b>Mod. E</b>	Electronic counter for fiscal applications with optional preset and temperature compensation functions.
<b>Mod. F</b>	Intrinsically safe digital totalizer and flow indicator with optional pulse output and/or 4+20 mA output.
<b>Mod. K</b>	Explosion proof digital totalizer and flow indicator with optional pulse output and/or 4+20 mA output.
<b>Mod. H</b>	Hart transmitter with digital indicator (EEx-d or EEx-ia).

Outer Housing Materials		
Code	Body/Covers	Gaskets
<b>A</b>	Cast iron	Teflon
<b>B</b>	Bronze	Teflon
<b>C</b>	Carbon steel	Teflon
<b>D</b>	Ductile iron	Teflon
<b>E</b>	Aisi 304	Teflon
<b>F</b>	Aisi 316	Teflon
<b>G</b>	Aisi 316L	Teflon
<b>H</b>	Low temperat. Carbon steel	Teflon

Transmission of movement is normally of magnetic type for all the codes.

#### Counter Models



Mod. 12

Mod. 22



Mod. VR

Mod. F/H



Mod. K/H

Mod. E

Measuring Unit Materials		
Code	Housing	Rotors
<b>1</b>	Bronze	Bronze
<b>2</b>	Bronze	Aluminum
<b>3</b>	Cast Iron	Aluminum
<b>5</b>	Cast Iron	Cast Iron
<b>7</b>	Aisi 304	Aisi 304
<b>8</b>	Aisi 316	Aisi 316
<b>9</b>	Aisi 316L	Aisi 316L

Bearings are normally made of carbon while rotor shafts and timing gears are in stainless steel.

Max Pressure	
Code	MPa
A	1
L	2
M	6,2
H	11
X	>11



## PD Flowmeters since 1970

### Double Case PD Flowmeters

Flow Rate Ranges (m <sup>3</sup> /h)											
Mod.	Ø line	mPa.s Service	Petroleum products				Water	Chemical products			
			> 0,5	2	10	150	T < 80 °C	Soda 30%	50	500	2000
51	25	Continuous	0,6 ÷ 2,5	0,5 ÷ 2,5	0,2 ÷ 3,5	0,05 ÷ 3,5	0,5 ÷ 2,3	0,2 ÷ 2,5	0,1 ÷ 3,5	0,02 ÷ 2,5	0,008 ÷ 2
	40	Intermittent	0,6 ÷ 3,5	0,5 ÷ 3,5	0,2 ÷ 4	0,05 ÷ 4	0,5 ÷ 2,8	0,2 ÷ 3,5	0,1 ÷ 4	0,02 ÷ 3,5	0,008 ÷ 2,5
11	25	Continuous	1 ÷ 4,5	0,8 ÷ 4,5	0,3 ÷ 6	0,07 ÷ 6	0,9 ÷ 4	0,3 ÷ 4,5	0,15 ÷ 6	0,04 ÷ 4,5	0,015 ÷ 3,5
	40	Intermittent	1 ÷ 6	0,8 ÷ 6	0,3 ÷ 7	0,07 ÷ 7	0,9 ÷ 5	0,3 ÷ 6	0,15 ÷ 7	0,04 ÷ 6	0,015 ÷ 4,5
12	40	Continuous	2 ÷ 9	1,5 ÷ 9	0,6 ÷ 13	0,15 ÷ 13	1,8 ÷ 8,5	0,6 ÷ 9	0,3 ÷ 13	0,08 ÷ 9	0,03 ÷ 7,5
	50	Intermittent	2 ÷ 13	1,5 ÷ 13	0,6 ÷ 15	0,15 ÷ 15	1,8 ÷ 10,5	0,6 ÷ 13	0,3 ÷ 15	0,08 ÷ 13	0,03 ÷ 9
22	50	Continuous	2,5 ÷ 14	2 ÷ 14	1 ÷ 20	0,25 ÷ 20	2,3 ÷ 13	1 ÷ 14	0,5 ÷ 20	0,12 ÷ 14	0,05 ÷ 12
	65	Intermittent	2,5 ÷ 20	2 ÷ 20	1 ÷ 24	0,25 ÷ 24	2,3 ÷ 16,5	1 ÷ 20	0,5 ÷ 24	0,12 ÷ 20	0,05 ÷ 14
53	50	Continuous	5 ÷ 25	4 ÷ 25	2 ÷ 35	0,5 ÷ 35	4,5 ÷ 22,5	2 ÷ 25	1 ÷ 35	0,25 ÷ 25	0,1 ÷ 20
	80	Intermittent	5 ÷ 35	4 ÷ 35	2 ÷ 40	0,5 ÷ 40	4,5 ÷ 28	2 ÷ 35	1 ÷ 40	0,25 ÷ 35	0,1 ÷ 25
13	50	Continuous	6,5 ÷ 35	5 ÷ 35	2,5 ÷ 50	0,6 ÷ 50	6 ÷ 34	2,5 ÷ 35	1,2 ÷ 50	0,3 ÷ 35	0,12 ÷ 30
	80	Intermittent	6,5 ÷ 50	5 ÷ 50	2,5 ÷ 60	0,6 ÷ 60	6 ÷ 42	2,5 ÷ 50	1,2 ÷ 60	0,3 ÷ 50	0,12 ÷ 35
14	80	Continuous	13 ÷ 65	10 ÷ 65	4,5 ÷ 90	1,2 ÷ 90	12 ÷ 60	4,5 ÷ 65	2,3 ÷ 90	0,6 ÷ 65	0,25 ÷ 55
	100	Intermittent	13 ÷ 90	10 ÷ 90	4,5 ÷ 110	1,2 ÷ 110	12 ÷ 75	4,5 ÷ 90	2,3 ÷ 110	0,6 ÷ 90	0,25 ÷ 65
24	80	Continuous	18 ÷ 90	14 ÷ 90	6 ÷ 125	1,5 ÷ 125	16 ÷ 80	6 ÷ 90	3 ÷ 125	0,75 ÷ 90	0,3 ÷ 75
	100	Intermittent	18 ÷ 125	14 ÷ 125	6 ÷ 150	1,5 ÷ 150	16 ÷ 100	6 ÷ 125	3 ÷ 150	0,75 ÷ 125	0,3 ÷ 90
16	100	Continuous	24 ÷ 110	18 ÷ 110	8 ÷ 150	2 ÷ 150	20 ÷ 100	8 ÷ 110	4 ÷ 150	1 ÷ 110	0,4 ÷ 90
	150	Intermittent	24 ÷ 150	18 ÷ 150	8 ÷ 180	2 ÷ 180	20 ÷ 125	8 ÷ 150	4 ÷ 180	1 ÷ 150	0,4 ÷ 110
18	150	Continuous	35 ÷ 150	25 ÷ 150	12 ÷ 210	3 ÷ 210	30 ÷ 140	12 ÷ 150	6 ÷ 210	1,5 ÷ 150	0,6 ÷ 125
	200	Intermittent	35 ÷ 210	25 ÷ 210	12 ÷ 250	3 ÷ 250	30 ÷ 175	12 ÷ 210	6 ÷ 250	1,5 ÷ 210	0,6 ÷ 150
28	150	Continuous	40 ÷ 190	30 ÷ 190	15 ÷ 270	4 ÷ 270	35 ÷ 180	15 ÷ 190	7,5 ÷ 270	2 ÷ 190	0,8 ÷ 160
	200	Intermittent	40 ÷ 270	30 ÷ 270	15 ÷ 320	4 ÷ 320	35 ÷ 225	15 ÷ 270	7,5 ÷ 320	2 ÷ 270	0,8 ÷ 190
110	200	Continuous	60 ÷ 270	40 ÷ 270	20 ÷ 380	4,5 ÷ 380	50 ÷ 260	20 ÷ 270	10 ÷ 380	2,5 ÷ 270	2,5 ÷ 230
	250	Intermittent	60 ÷ 380	40 ÷ 380	20 ÷ 450	4,5 ÷ 450	50 ÷ 315	20 ÷ 380	10 ÷ 450	2,5 ÷ 380	2,5 ÷ 265
112	250	Continuous	80 ÷ 350	60 ÷ 350	25 ÷ 500	6,5 ÷ 500	70 ÷ 330	25 ÷ 350	12,5 ÷ 500	3,5 ÷ 350	3,5 ÷ 295
	300	Intermittent	80 ÷ 500	60 ÷ 500	25 ÷ 600	6,5 ÷ 600	70 ÷ 415	25 ÷ 500	12,5 ÷ 600	3,5 ÷ 500	3,5 ÷ 350
212	250	Continuous	130 ÷ 600	100 ÷ 600	45 ÷ 850	10 ÷ 850	120 ÷ 570	45 ÷ 600	22,5 ÷ 850	5 ÷ 600	5 ÷ 500
	300	Intermittent	130 ÷ 850	100 ÷ 850	45 ÷ 1000	10 ÷ 1000	120 ÷ 700	45 ÷ 850	22,5 ÷ 1000	5 ÷ 850	5 ÷ 600
612	300	Continuous	160 ÷ 850	125 ÷ 850	60 ÷ 1200	14 ÷ 1200	140 ÷ 810	60 ÷ 850	30 ÷ 1200	7 ÷ 850	7 ÷ 715
	350	Intermittent	160 ÷ 1200	125 ÷ 1200	60 ÷ 1400	14 ÷ 1400	140 ÷ 1000	60 ÷ 1200	30 ÷ 1400	7 ÷ 1200	7 ÷ 840
114	350	Continuous	200 ÷ 1350	150 ÷ 1350	75 ÷ 2000	18 ÷ 2000	180 ÷ 1250	75 ÷ 1300	38 ÷ 2000	9 ÷ 1300	9 ÷ 1110
	400	Intermittent	200 ÷ 2000	150 ÷ 2000	75 ÷ 2160	18 ÷ 2160	180 ÷ 1500	75 ÷ 2000	38 ÷ 2160	9 ÷ 2000	9 ÷ 1250

Ø Line is the dimension of the flange coupled to the pipe

### Notes on Flange Identification Code

Flange size different from standard flange size identified from the digits just after the first digit of each model (i.e. 51: 1" flange, 110: 10" flange) are identified adding the below code after PD Flowmeter model:

- S:1/2", CD:3/4", A:1", AA:1"1/4, AB:1"1/2, B:2", BC:2"1/2, C:3", D:4", F:6", H:8", L:10", P:14", R:16" (i.e model 16D is flanged 4")

### Notes on Flow Rate Ranges

It is possible to use "PETROL" PD flowmeters outside specified flow rate ranges and viscosities but in such cases it is necessary to consult the factory. Intermittent service means up to 8 hours of operation per day (365 days per year), while Continuous service means more than 8 hours of operation per day (365 days per year).

For liquid with a viscosity above 10 cP is normally specified a 1:10 flow rate range within the limits mentioned in the table.

# PETROL<sup>®</sup>

**PD Flowmeters since 1970**

## Double Case PD Flowmeters

### Pd Flowmeters Outline Dimensions

Version With Horizontal Rotor Shafts

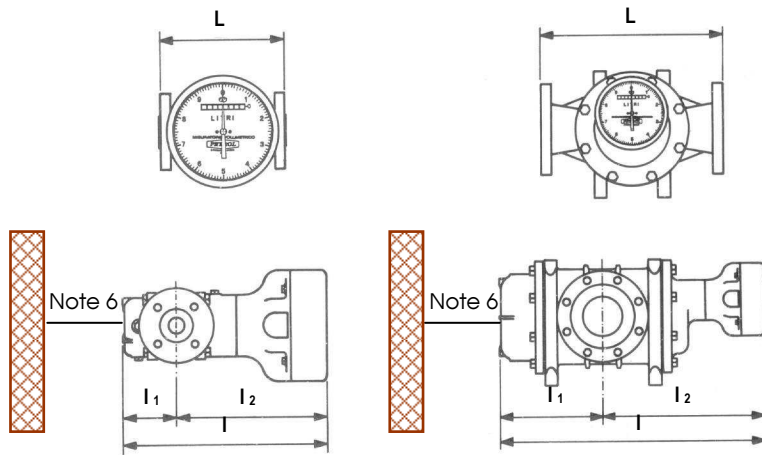

Mod.	L	I	I1	I2
51	200	311	78	233
11	200	329	86	243
12	250	375	110	265
22	250	425	135	290
53	320	432	148	284
13	320	492	178	314

Version With Vertical Rotor Shafts

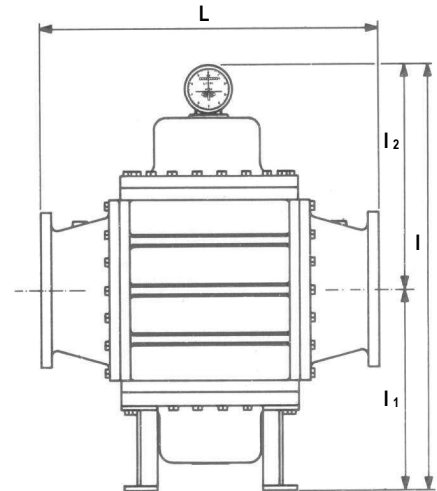

Mod.	L	I	I1	I2
14	380	564	209	355
24	450	655	255	400
16	610	703	243	460
18	610	793	288	505
28	640	889	335	554
110	640	889	335	554
112	650	1138	511	627

Mod.	L	I	I1	I2
212	1200	1423	678	745
612	1305	1623	778	845
114	1400	1723	828	895

Dimensions valid for Pd Flowmeters flanged ANSI 150 RF and UNI PN 10/16

Dimensions and characteristics subject to change without notice.

### Calibration Lab

The Petrol Instruments Calibration Laboratory is a facility composed by n.4 tank provers (10.000, 5.000, 1.000 and 100 litres) attested by Italian Metric Office. Every Petrol Instruments PD Flowmeter is calibrated in this laboratory ensuring that meter performance are respected before delivery the same to our customers.

### Main Application Fields

- ✓ Petroleum Industry
- ✓ Petrochemical Industry
- ✓ Chemical Industry
- ✓ Pharmaceutical Industry
- ✓ Crude Oil Extraction
- ✓ Power Plants Industry
- ✓ Ships and Steel Making Industry

Please consult factory for special applications

### Typical Installations

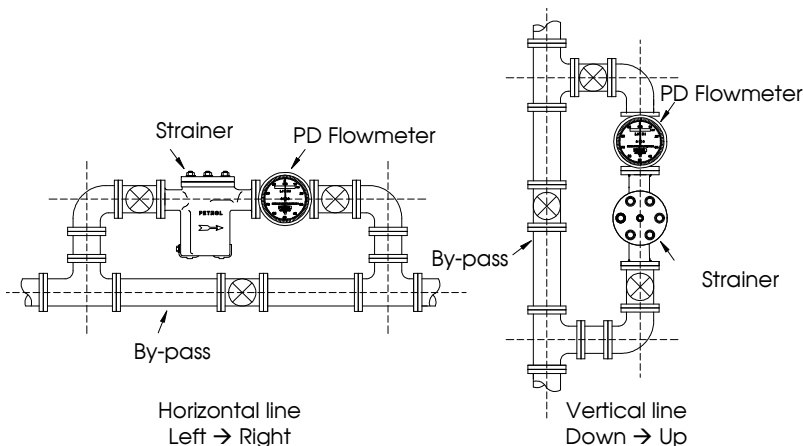



## PD Flowmeters since 1970

### Double Case PD Flowmeters



#### Specialist

During the years "PETROL INSTRUMENTS" has accumulated a very strong experience to allow also the production of PD flowmeters suitable for the heaviest operating conditions in the more different industrial fields such as: the measurement of blood, of phthalic and of maleic anhydride, of crude oil on well-heads, of heavy oils at high temperatures and of sea water.

Such a technical background and the investments yearly destined to the research in the field of the volumetric measurement of liquids have till now satisfied each particular need of the customers. Here below there are some pictures of PD flowmeters for special applications and after are listed the most significant references for crude oil extraction industry and for power generation plants.



#### Homologations

- ✓ Approval n. 347828 issued by Italian Weight and Measure Department, for legal and custody transfer applications in Italy
- ✓ Approval n. 10596 issued by Italian Weight and Measure Department, for the legal application in Italy of the "Master Meters Petrol Instruments"
- ✓ Compliance with OIML R117 and API MPMS
- ✓ Metrological Approval n. 57385 issued by the Russian Authority, for the legal use in Russia
- ✓ MIGAS Approval issued by the Indonesian Authority for the legal use in Indonesia
- ✓ DPR Approval issued by Department of Petroleum Resources for the legal use in Nigeria
- ✓ Approval issued by AQSIQ (PAC) for the legal use in China
- ✓ Hellenic Metrology Approval issued by the Hellenic Authority, for the legal use in Greece
- ✓ MID Evaluation Certificate n. MID\_127\_EC\_01 rev.0 (Class 0,3) for Petrol Instruments PD Meters issued by KIWA
- ✓ MID EU-Type Examination Certificate Module B n. MID\_127\_B\_1 rev.0 for Petrol Instruments Measuring System for continuous and dynamic measurement of industrial liquids issued by KIWA
- ✓ NMIM/SIRIM Approval issued by NMIM for the legal use in Malaysia
- ✓ Kazakhstan Pattern Approval for the legal use in Kazakhstan
- ✓ Approval n. 0425 PED 004264-00 Rev.0 issued by ICIM, attesting the conformity of our products to the PED directive n. 2014/68/EU.
- ✓ LR Type Approval certificate n. LR2004671TA Rev.0 for Petrol Instruments PD meters issued by Lloyd's Register
- ✓ EC Declaration of Conformity (ATEX, PED),
- ✓ ISO 9001:2015 Certificate issued by Bureau Veritas Italia
- ✓ ISO 14001:2015 Certificate n. E1204 issued by Audiso
- ✓ ISO 45001:2018 Certificate n. O989 issued by Audiso





## **PETROL Instruments S.r.l.**

Via della Tecnica, n. 5 - 04011 Aprilia (LT) - ITALY

Phone +39-06-9201.941 a.r. - Fax +39-06-9201.9446

<http://www.petrol-instruments.com> - e-mail: [info@petrol-instruments.com](mailto:info@petrol-instruments.com)

